

# Qcom

## SPECIFICATIONS

MiniPCI 802.11g Type IIIB Module

Q802MKG2

Ver. 2A

Date: 10/26/2006

**Prepared by : Qcom Technology Inc.**

**Approved by :**

## **Contents:**

### 802.11b/g Wireless LAN

- Device Description
- Features
- Specification Compliance
- Form Factor
- Block Diagram
- Modulation Methods
- Channel Assignment
- Security (WEP Key)
- Electrical Specifications
- Software & OS support
- LED Indication
- Antenna connector
- Regulation
- Operating Condition

## **Device Description**

The QCOM Q802MKG2 is a complete wireless high speed Network Interface Card. It conforms to the IEEE 802.11g and 802.11b protocol and operates in the 2.45GHz frequency bands. The design is based on Ralink Chipset: RT2561 MAC/BBP, RT2527 Transceiver.

## **Features**

- Ralink RT2561 Chipset
- Support IEEE 802.11b and 802.11g standards
- Support Security mode: 64/128 WEP, TKIP, WPA, WPA2, 802.11i
- Support Ad hoc and Infrastructure both network architectures
- Support for 54, 48, 36, 24, 18, 12, 9, and 6Mbps OFDM, 11 and 5.5Mbps CCK and legacy 2 and 1Mbps data rates.
- Support two antenna connectors
- Driver Supports Win98SE, ME, XP, and 2000

## **Specification Compliance**

- IEEE 802.11b
- IEEE 802.11g
- PCI Bus Interface Spec. 2.2
- MiniPCI Spec. 1.0

**Form Factor**

- MiniPCI Type III B
- Weight 13g
- Dimension: 44.45 +/- 0.15 x 59.60 +/- 0.15 x 4.8mm (L x W x H)

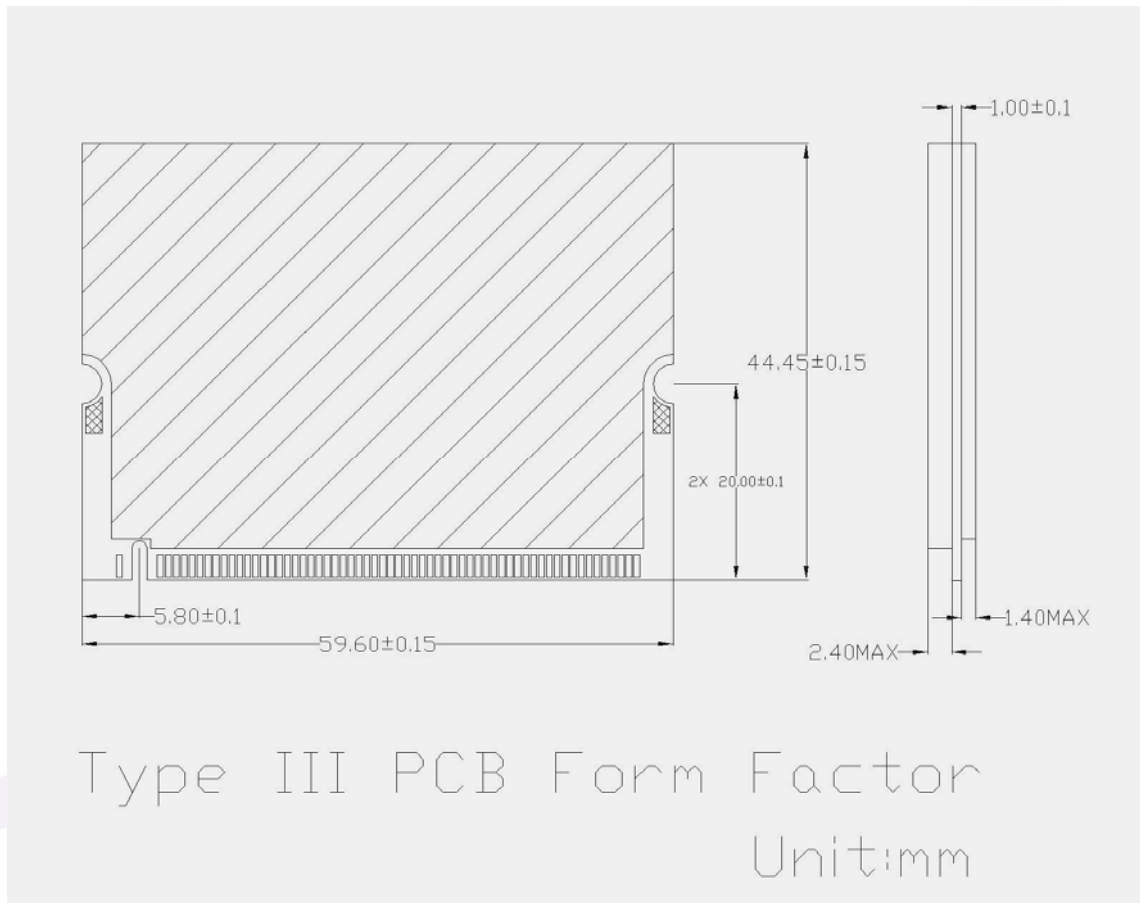

## Q802MKG2 Block Diagram

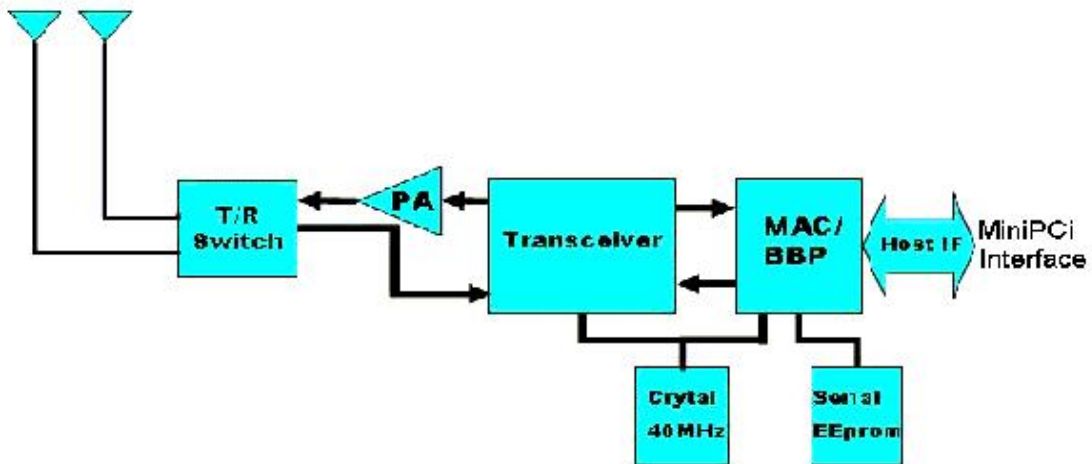

RT2561: MAC/Baseband Processor for IEEE 802.11b/g

RT2527: Single band direct conversion transceiver with AGC and synthesizer

The Q802MKG2 comprises a combination baseband processor/medium access controller (RT2561); modulator/demodulator (RT2527); power amplifier; single chip, and various RF filter, and switch components.

## Modulation Methods

DATA BIT RATE	MODULATION and Encoding Rate
<b>802.11b CCK MODES</b>	
1Mbps	BPSK
2Mbps	QPSK
5.5Mbps	QPSK
11Mbps	QPSK
<b>802.11g OFDM MODES</b>	
6Mbps	BPSK
9Mbps	BPSK
12Mbps	QPSK
18Mbps	QPSK
24Mbps	16QAM
36Mbps	16QAM
48Mbps	64QAM
54Mbps	64QAM

## **Channel Assignment**

<b>CHANNEL NUMBER</b>	<b>CHANNEL FREQUENCY</b>	<b>GEOGRAPHIC USAGE</b>
1	2412MHz	US, CA, EU, JP
2	2417MHz	US, CA, EU, JP
3	2422MHz	US, CA, EU, JP
4	2427MHz	US, CA, EU, JP
5	2432MHz	US, CA, EU, JP
6	2437MHz	US, CA, EU, JP
7	2442MHz	US, CA, EU, JP
8	2447MHz	US, CA, EU, JP
9	2452MHz	US, CA, EU, JP
10	2457MHz	US, CA, EU, JP
11	2462MHz	US, CA, EU, JP
12	2467MHz	EU, JP
13	2472MHz	EU, JP
14	2484MHz	JP

**KEY:**

**US = United States, CA = Canada, EU = European Countries (except France and Spain)**

**JP = Japan**

**Many countries and region are currently revising the channel assignment.**

## **Security**

- Support 64 bit WEP in all data rate modes.
- Support 128 bit 128RC4 algorithm in all data rate modes.
- Support TKIP, WPA, WPA2, 802.11i

## Electrical Specifications

RF Characteristics	Minimum	Typical	Maximum	Units
PC Interface		MiniPCI		
Plug and Play Compatible		No		
Internal Antenna Impedance		50		ohms
Environment Temperature Range	0		65	°C
Storage Temperature Range	-20		+85	°C
Supply Voltage	3.0	3.3	3.6	V
RX Supply Current (CCK)	232	239	239	mA
RX Supply Current (OFDM)	231	235	233	mA
TX Supply Current (CCK)	332	360	389	mA
TX Supply Current (OFDM)	300	319	351	mA
WMM Power Save Mode		44(rms)		mA
RX Sensitivity, 1 Mbps(CCK)		89		dBm
RX Sensitivity, 2 Mbps(CCK)		89		dBm
RX Sensitivity, 5 Mbps(CCK)		85		dBm
RX Sensitivity, 11 Mbps(CCK)		83		dBm
RX Sensitivity, 6/9Mbps (OFDM)		86		dBm
RX Sensitivity, 12/18Mbps(OFDM)		82		dBm
RX Sensitivity, 24/36Mbps(OFDM)		75		dBm
RX Sensitivity, 48/54Mbps(OFDM)		70		dBm
TX Output Power(CCK)	14	16	18	dBm
TX Output Power(OFDM)	11	13	15	dBm
TX Carrier Suppression		23		dB
TX Spectral Mask (CCK)		PASS		
TX Spectral Mask (OFDM)		PASS		
Preamble Length		Long/Short		

■ **Note: Sensitivity based upon 1 kbyte packet length, 8% PER(CCK), single antenna driven, diversity disabled.**

**Note: Sensitivity based upon 1 kbyte packet length, 10% PER(OFDM), single antenna driven, diversity disabled.**

**Note: All measurements at the end of 6" of cable through Murata Connector with local diversity option.**

**Software & OS support**

OS	Driver
Win98SE	Available
Windows Millennium	Available
Win2000	Available
WinXP	Available
User Configuration Utility	Available

**LED Indication**

	ON	BLINKING	OFF
LED1	Associated with AP/STA(Ad-hoc)	Searching AP/STA	Disassociated
LED2		TX/RX	Disassociated

**Q802MKG2 supports two LED indicators (Figure 1. LED1 and LED2). LED1 indicates the hardware radio on/off status with WLAN link status and LED2 indicates WLAN activity status.**

**LED schematic Suggestion:**

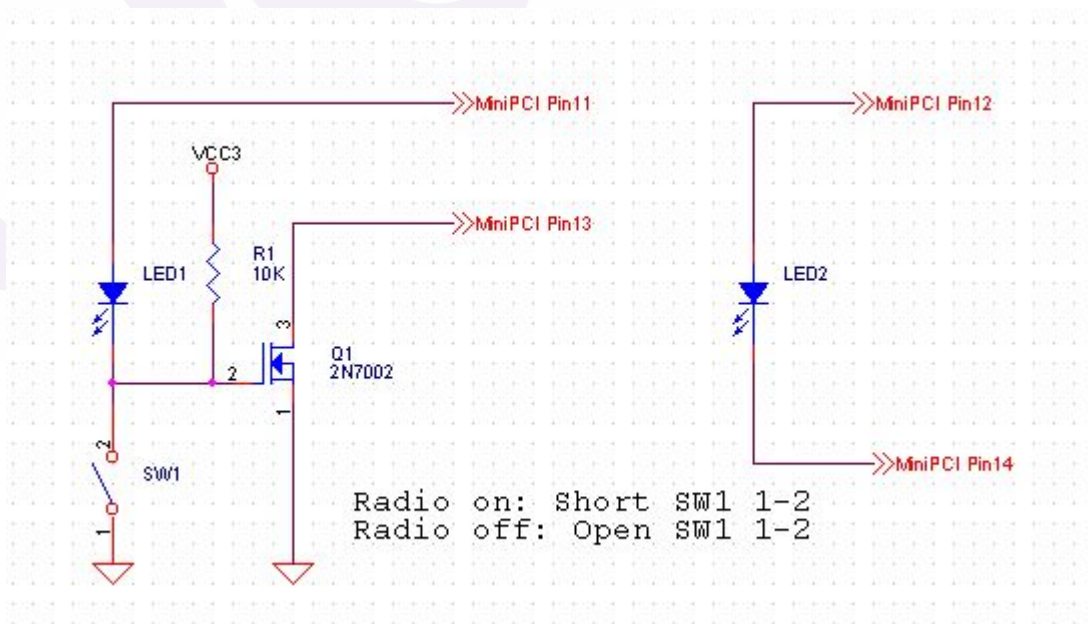

Figure 1.

**Antenna Connector**

- Antenna Connector, two pieces
- SMT Ultra Miniature Coax Connector, Hirose, CL331-0471-0-10 (U.FL-R-SMT) or compatible

**Regulation**

Upon requested

**Operating Conditions**

Voltage Range	<b>3.3V +-0.3V</b>
Environment Temperature Range	<b>0°C - 65°C</b>
Storage Temperature Range	<b>-20°C - 85°C</b>
Relative Humidity during Operating	<b>95%</b>
Relative Humidity during Storage	<b>95%</b>