



SPECIFICATIONS

GPS Module

LG100RA2

Ver. 2A

Date: 12/18/2006

Prepared by: Qcom Technology Inc.
Approved by:

Contents:

Introduction

Feature

Block Diagram

Mechanical Dimension

Technical Specifications

Connector Type

Host Interface Pin Definition

Operating Conditions

Introduction

The Qcom LG100RA2 GPS module is compact size, high sensitivity, and lower power consumption solution for portable system vendor who plans to integrate GPS function into their product line. The LG100RA2 is based on ATMEL high performance ANTARIS4 GPS single chip solution which is featured with high sensitivity and extremely fast TTFF's at low signal level. The Qcom LG100RA2 provides an approach for system vendor to short the Time-to Market for GPS related application.

Feature

- Base on high performance ATMEL ANTARIS4 single chip solution
- Compact Size: 27.41 X 23.57 mm +- 0.15mm
- TTL level serial port for host interface
- Baud rate 57.6 (kBaud), Auto enabled
- Support NMEA, UBX Binary and RTCM Protocol
- Supports SBAS (WAAS, EGNOS, MSAS) **(Option)**
- 1 USB Device Port – Universal Serial USB 2.0 Full-speed
- Time to First Fix: 34s (Cold Start)
- 16-channel GPS Correlator
- Antenna connector (MMCX or I-PEX) supports active antenna
- Single LED indicator support for GPS status

Block Diagram

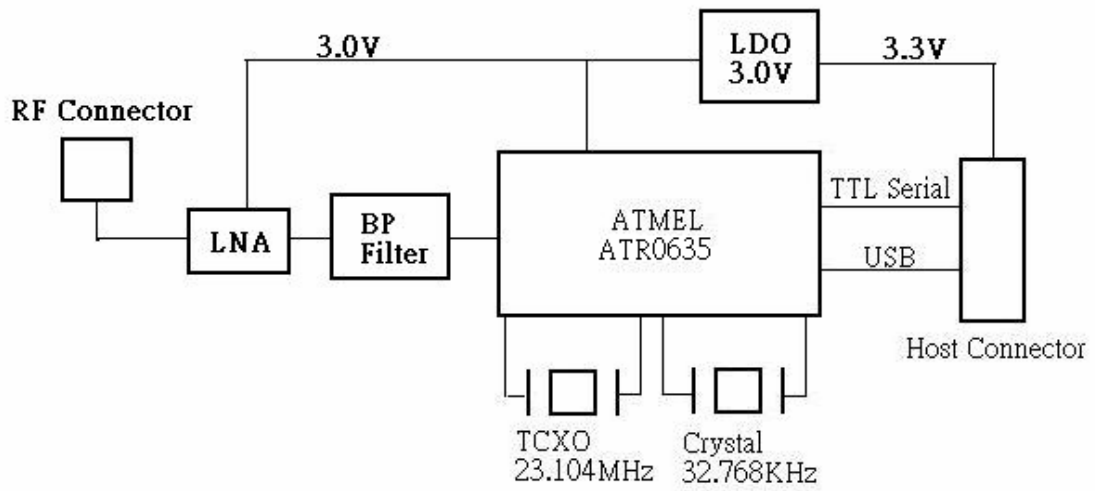

Mechanical Dimension

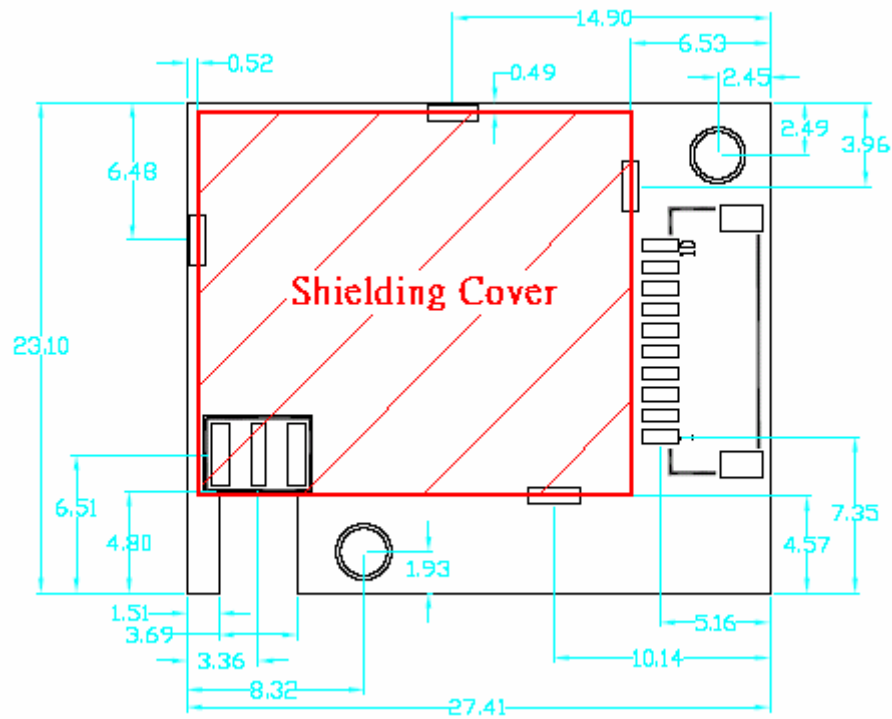

Technical Specifications

Chipset	ATMEL ATR0635	
General	Frequency	1.575.42MHz
	C/A code	1.023MHz
	Channel	16
Position Accuracy	CEP	2.5m
	CEP DGPS/WAAS/EGNOS	2.0m
	Time	50ns RMS
Acquisition Times	Reacquisition	<1 sec
	Aided start	4 sec
	Host start	<3.5 sec
	Warm start	33 sec
	Cold start	34 sec
Dynamic Conditions	Altitude	<60,000ft(18,000meters)
	Velocity	<1,000knots (515m/s)
Host Interface (USB/TTL)	Input Protocol	UBX, NMEA, RTCM
	Output Protocol	NMEA
	Protocol message	GGA, RMC, GSA, GSV
	Baud Rate	57600bps, Auto enabled
	Parity	None
	Stop Bits	1
	Data Bits	8
Power	3.3V	48mA
	Vbat	7uA

Connector Type

Connector	Vendor	Part#
Host	ACES	87213-1000L, or compliance
Antenna	ALINER	MMCX Jack 25-006A
	I-PEX (option)	20279-001E-01

Host Interface Pin Definition

Pin#	Signal name	Description
1	USB D+	USB D+ signal
2	USB D-	USB D- signal
3	GND	Ground pin
4	LED	LED pin
5	TX	Output pin. UART TX signal. (TTL Level)
6	RX	Input pin. UART RX signal. (TTL Level)
7	Vbat	Provide the RTC and backup SRAM form 1.5V ~ 3.6V input voltage.
8	3.3V	Positive support for whole module
9	Reset#	Input pin. External signal to reset the module. Low active.
10	GND	Ground pin

Operating Conditions

Voltage Range	3.3 +-0.3V
Operating Temperature Range	0 ~ 70°C
Storage Temperature Range	- 20 ~ 85°C
Relative Humidity During Operating	95%
Relative Humidity During Storage	95%

LED Status

LED status	GPS card activity
LED on	GPS work, not Fixed.
LED Blink	GPS Fixed Ready
LED off	All other status