



SPECIFICATION

Bluetooth 2.0 + EDR Class 2 Module

QBTM500
(Draft !)

Ver. 1A1
Date: 6/20/2007

Prepared by : Qcom Technology Inc.

Approved by :

Contents:

1. Device Overall Description
2. Bluetooth
 - Features
 - Specification Compliance
 - Bluetooth Block Diagram
 - Modulation Methods
 - Channel Assignment
 - RF Characteristics
 - Power Consumption
 - Regulation
3. Mechanical Dimension
4. Pinout and Definition

Device Overall Description

- Bluetooth™ version 2.0 + EDR compliant & eSCO support
- AFH (Adaptive Frequency Hopping) to avoid interference in the same ISM band
- Small footprint
- Bluetooth™ Class 2 operation (up to 10 meter range)
- Built-in Printed PCB Antenna (Optional External Antenna)
- Surface mountable
- CSR BlueCore5-Multimedia, single chip Bluetooth™ system with built-in Powerful 64 MIPS 24 bit Kalimba DSP Co-Processor
- 8/16 Mbits Flash Memory (depends on firmware requirement)
- 15 Digital I/O lines + 2 Analog I/O lines + 2 LED drivers
- Lithium ion/Polymer battery charger built-in
- USB 1.1 support (USB 2.0 compatible)
- UART support
- SPI interface for debug and Firmware flash
- Scatternet support
- Park, Sniff, Hold and Sleep low power modes
- 16-bit stereo Audio CODEC
- I2S/PCM , differential Audio In/Out Interfaces
- Built-in 1.8V, 1.5V regulator
- 2.9V to 6V Input depends on implementation
- RoHS compliant

Bluetooth

Specification Compliance

- Bluetooth Specification V2.0 + EDR compliant

Block Diagram

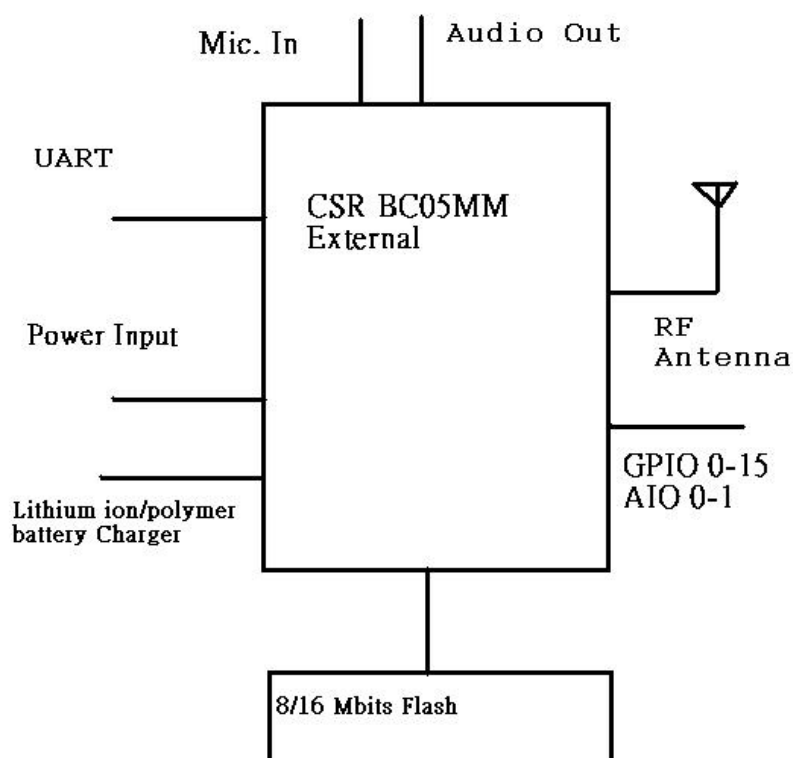

RF Characteristics

Bluetooth Spec. Class 2

Profiles support

- A2DP/Handfree/AVRCP based on original CSR BlueLab reference firmware.
- Further modification/development is upon request under additional charge.

Regulation

Depend on OEM customer requirement

Power consumption

TBD

Mechanical Dimension

35mm(L) * 18mm (W) * 3.5mm (H)

Pinout and Definition

Pin#	Pin name	Description
1	GND	Ground connection for RF circuit. No connected for PCB antenna version.
2	RF_OUT	RF signal input/output. No connected for PCB antenna version.
3	GND	Ground connection for RF circuit. No connected for PCB antenna version.
4	GND	Ground connection.
5	PIO0	Programmable input/output line.
6	PIO1	Programmable input/output line.
7	PIO3	Programmable input/output line.
8	PIO2	Programmable input/output line.
9	PIO12	Programmable input/output line.
10	GND	Ground connection.
11	PIO10	Programmable input/output line.
12	UART_RX	UART data input. No connected if this port is not used.
13	UART_TX	UART data output. No connected if this port is not used.
14	VDD_USB	3.3V Positive supply for UART/USB ports. No connect if these ports are not used.
15	AIO1	Analogue programmable input/output line.
16	AIO0	Analogue programmable input/output line.
17	GND	Ground connection.
18	USB_D-	USB data minus. No connected if this port is not used.
19	USB_D+	USB data plus. No connected if this port is not used.
20	PIO13	Programmable input/output line.
21	PIO15	Programmable input/output line.
22	PIO9	Programmable input/output line.
23	PIO11	Programmable input/output line.
24	GND	Ground connection.
25	PIO7	Programmable input/output line.
26	PIO5	Programmable input/output line.
27	PIO4	Programmable input/output line.
28	PIO6	Programmable input/output line.
29	PIO14	Programmable input/output line.
30	PIO8	Programmable input/output line.
31	GND	Ground connection.
32	PCM_SYNC	Synchronous data sync.
33	PCM_OUT	Synchronous data output.
34	PCM_IN	Synchronous data input.

35	PCM_CLK	Synchronous data clock.
36	LED0	LED driver. Open drain output.
37	LED1	LED driver. Open drain output.
38	GND	Ground connection.
39	VBUS (1.)	Lithium ion/polymer battery charger input.
40	VBUS (1.)	Lithium ion/polymer battery charger input.
41	PWR_HOOK/Pair Button	Power on/off module.
42	RST#	Reset if low. It must be low for >5ms to cause a reset.
43	SPI_MOSI	SPI data input.
44	SPI_CS#	SPI chip select, active low.
45	SPI_CLK	SPI clock.
46	SPI_MISO	SPI data output.
47	VBAT	Lithium ion/polymer battery positive terminal. Battery charger output and Battery input to this module.
48	VBAT	Lithium ion/polymer battery positive terminal. Battery charger output and Battery input to this module.
49	GND	Ground connection.
50	AGND	Ground connection for audio.
51	SPKR_R_N	Speaker output negative, right. Direct from BC5-MM chip ball.
52	SPKR_R_P	Speaker output positive, right. Direct from BC5-MM chip ball.
53	SPKR_L_N	Speaker output negative, left. Direct from BC5-MM chip ball.
54	SPKR_L_P	Speaker output positive, left. Direct from BC5-MM chip ball.
55	AGND	Ground connection for audio.
56	MIC_BIAS	Microphone bias.
57	MIC_R_P	Microphone input positive, right. Direct from BC5-MM chip ball.
58	MIC_R_N	Microphone input negative, right. Direct from BC5-MM chip ball.
59	MIC_L_P	Microphone input positive, left. Direct from BC5-MM chip ball.
60	MIC_L_N	Microphone input negative, left. Direct from BC5-MM chip ball.
61	AGND	Ground connection for audio.

(1.) The battery charger is designed to operate with a permanently connected battery. If the application permits the charger input to be connected while the battery is disconnected, then the BATH pin voltage may become unstable. This in turn may cause damage to the internal switch-mode regulator. Connecting a 470 μ F capacitor to BATH limits these oscillations thus preventing damage.

For detail, pls refer to CSR document

- CS-110839-AN, Bluetunes2 Stereo Bluetooth Headset Example Design
- CS-101568-DSP6 , BlueCore5-Multimedia External
- CS-114058-AN Issue 1.pdf for ESD Protection issues

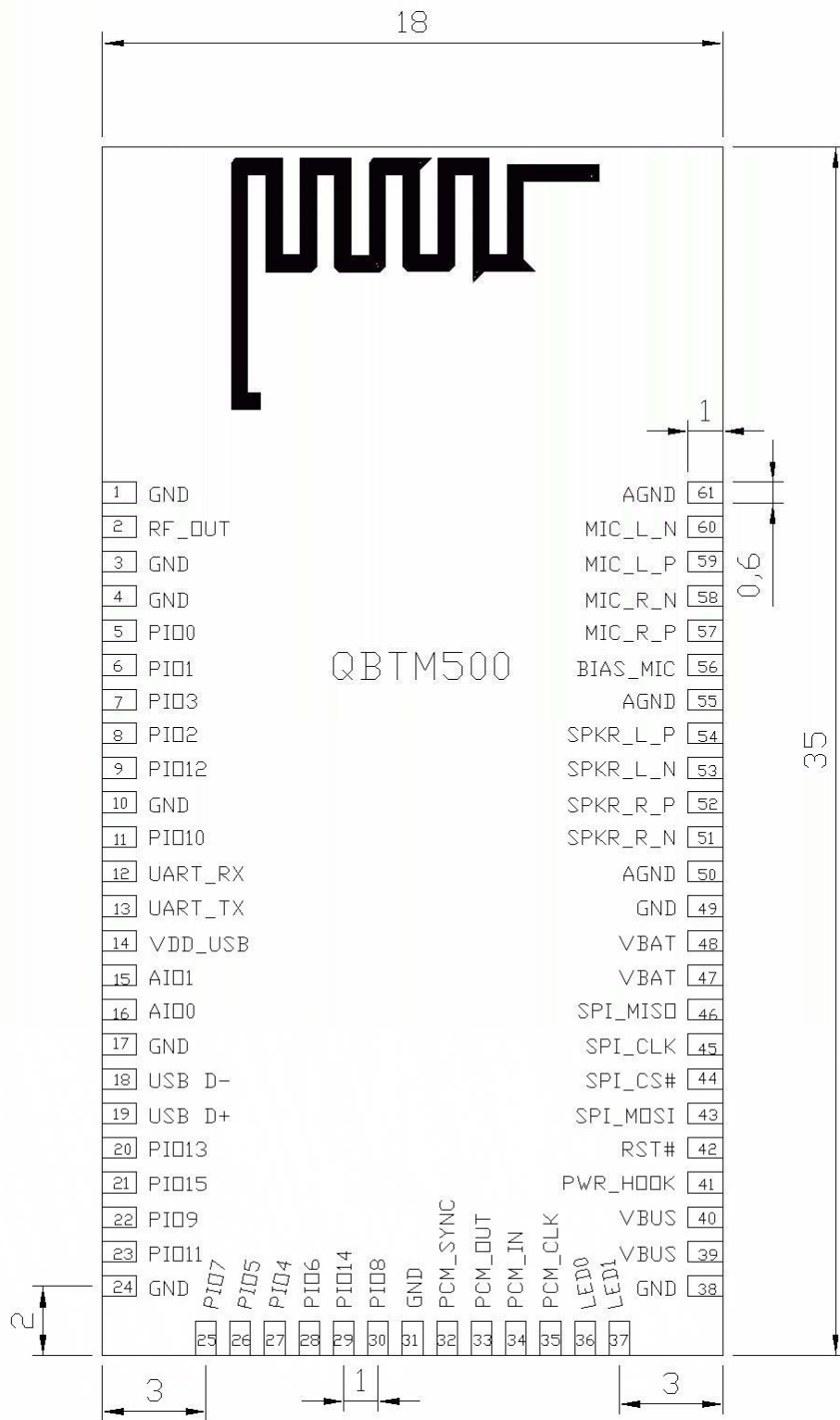

Top View